

EXTREME MODEL XT-SERIES HIGH SPEED SHRINK TUNNEL

Extreme's engineering team took it's 30 years of shrink packaging experience and focused on developing a high speed shrink tunnel that would meet the needs of today's demanding production environment. The unique chamber design and airflow system allow the operator complete control of the shrink process, whether the product and film require a gentle air flow or greater circulation for high speeds and high quality shrink. The innovative in chamber bottom pre-shrink gives control of seal placement. On thin products the seal can be placed on the edge or bottom of the package. The directional air flow controls eliminate dog ears and the small wrinkles left by other designs.



Standard Features with XT High Speed Shrink Tunnels

Heavy Duty 11 Gage Steel, Welded Construction

Bottom pre-shrink section in chamber controls seal placement on the package.

Choice of heavy duty wire belt or live roller conveyor; the wire belt is a zero maintenance item.

Digital temperature control maintains very precise internal temperatures.

AC variable frequency drive blower motor offers air flow control.

Directional air flow dampeners (8 zones) allows for product tuning.

Product viewing windows on both sides of tunnel gives a clear view of the shrink process.

Easy access to all components simplifies maintenance and repair.

XT18 Specifications:

Chamber Dimensions	21" Wide x 12.5" Tall x 73" Long
Conveyor Dimensions	18" Wide x 86" Long
Electrical Requirements	208/240 VAC, 60 Amps, 3 Phase, 60 HZ
Conveyor Speed	Up to 180 Feet per Minute
Operator Controls	Right Hand
Heater	15 KW

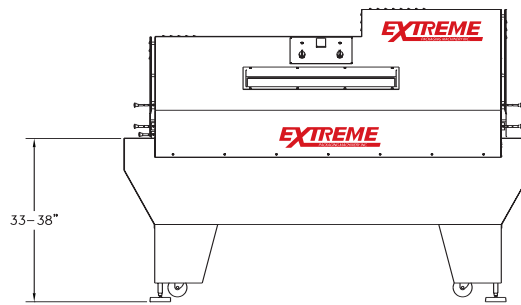
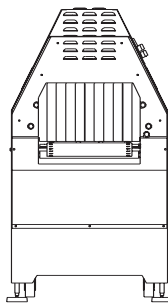
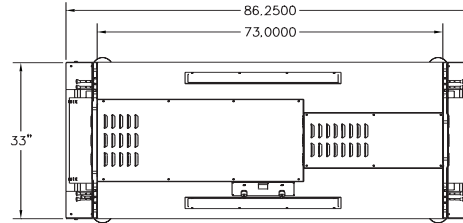

XT30 Specifications:

Chamber Dimensions	33" Wide x 16" Tall x 73" Long
Conveyor Dimensions	30" Wide x 86" Long
Electrical Requirements	208/240 VAC, 60 Amps, 3 Phase, 60 HZ
Conveyor Speed	Up to 180 Feet per Minute
Operator Controls	Right Hand
Heater	15 KW

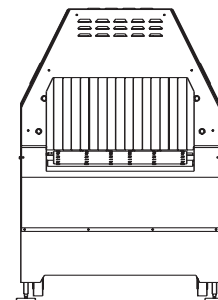
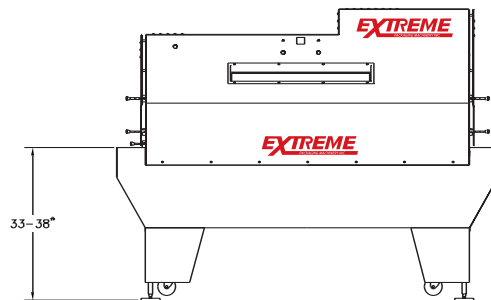
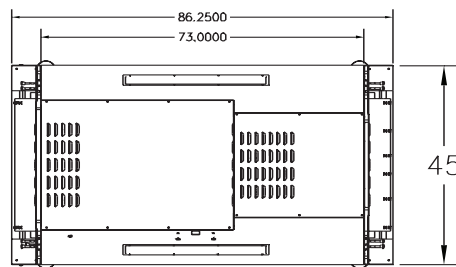

For more details including line layouts, infeed systems, other machines and videos visit our website.

Extreme Packaging Machinery, Inc: Phone: 949-888-7221 • 22831 Avenida Empresa • Rancho Santa Margarita, CA 92688