

# **SIGNODE** **HBX-4330**<sup>TM</sup>

**Automatic plastic strapping machine**

- **Unmatched simplicity**  
*Easy to operate and maintain*
- **Jam-resistant technology**
- **Bi-directional coil loading**

**Up to**  
**70**  
**straps per**  
**minute!**



Model is shown with optional features.

# SIGNODE HBX-4330™ Automatic plastic strapping machine

The new HBX-4330™ automatic strapping machine is the simplest, most reliable general-duty strapping machine on the market today. With 40% fewer parts and more timesaving features, the HBX-4330 machine simplifies operation and maintenance to save you time and money.

## Unmatched simplicity

The HBX-4330's simple yet durable design eliminates the use of drive belts and clutches. This combined with other trouble-free maintenance elements like toolless hot knife removal and jam-resistant technology make it easier to operate and more cost effective to maintain than other strapping machines.

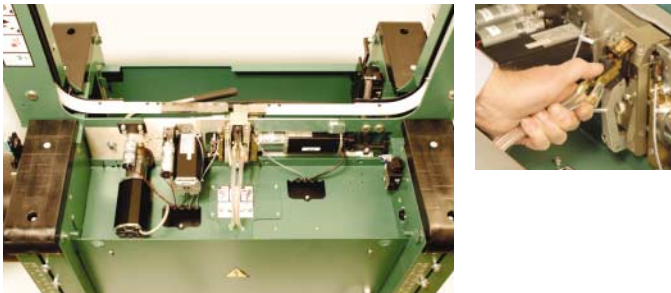

## Bi-directional coil loading

Strap coil pays off from either direction, eliminating the downtime and material waste resulting from incorrect coil loading.

## Out-of-strap feature

The out-of-strap feature ejects the strap at the end of the coil to eliminate downtime and errors associated with removing the excess strap left in the machine.

## Variable speed conveyor

The HBX-4330's standard variable speed reversible conveyor easily integrates with your existing conveyor system, providing for easy set-up and operation.

## Fully accessible strap path

No tools required. Simply raise the tabletop and lift guide for access to strap path.



## Toolless conveyor removal

Conveyors can be easily removed for maintenance.

## Automatic cut-off and refeed option

Signode's patented automatic cut-off and refeed feature automatically ejects misfed strap, rethreads itself and continues strapping without operator intervention.

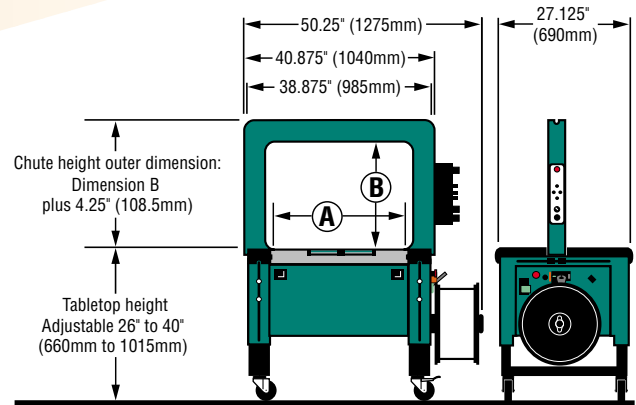

### HBX-4330 Chute inner dimensions

	in.	mm	in.	mm	in.	mm	in.	mm
A*	20	510	28	710	33	840	48	1220
B	15	380	20	510	30	760	20	510

\*Inner dimension A is maximum package size.

### HBX-4330 Specifications

**Cycle rate:** Up to 70 straps per minute. Actual production will vary depending on package size, chute size and operator dexterity.

**Maximum package weight:** 100 lbs on machine or conveyor

**Maximum applied tension:** Up to 250 lbs (1110 N)

**Strapping:** 9mm or 12mm Contrax polypropylene strapping

**Electrical requirements:**

120 volt, 60Hz, FLA 9.0 amp; 3 phase optional

**Shipping weight:** 600 lbs

### HBX-4330 Options

- Single or dual compression  
Single: Up to 120 lbs at 90 lbs psi  
Dual: Up to 240 lbs at 90 lbs psi
- Indicator light alerts operator to low strap/out-of-strap conditions and machine malfunction
- EZ height adjustable leg kit — 26" to 40" (660mm to 1015mm)
- Automatic cut-off and refeed
- Conveyor interlock kit

*The HBX-4330 is also available in a stainless steel model as well as a semiautomatic model, the HBX-4300.*

### Save on strapping costs with HB Series plastic strapping

The new HBX-4330 utilizes Signode's newest Contrax® polypropylene strapping. HB Series strapping has the same durable properties as regular Contrax with more strap per coil.

- HB 612 9mm Contrax coils — 16,000 feet per coil
- HB 812 12mm Contrax coils — 12,000 feet per coil

**SIGNODE®**

3610 West Lake Avenue  
Glenview, Illinois 60026  
1-800-323-2464  
www.signode.com