

MIP-1800 PUSHER BAR TENSIONER

**Keep tool well oiled.
Tighten screws
regularly.**

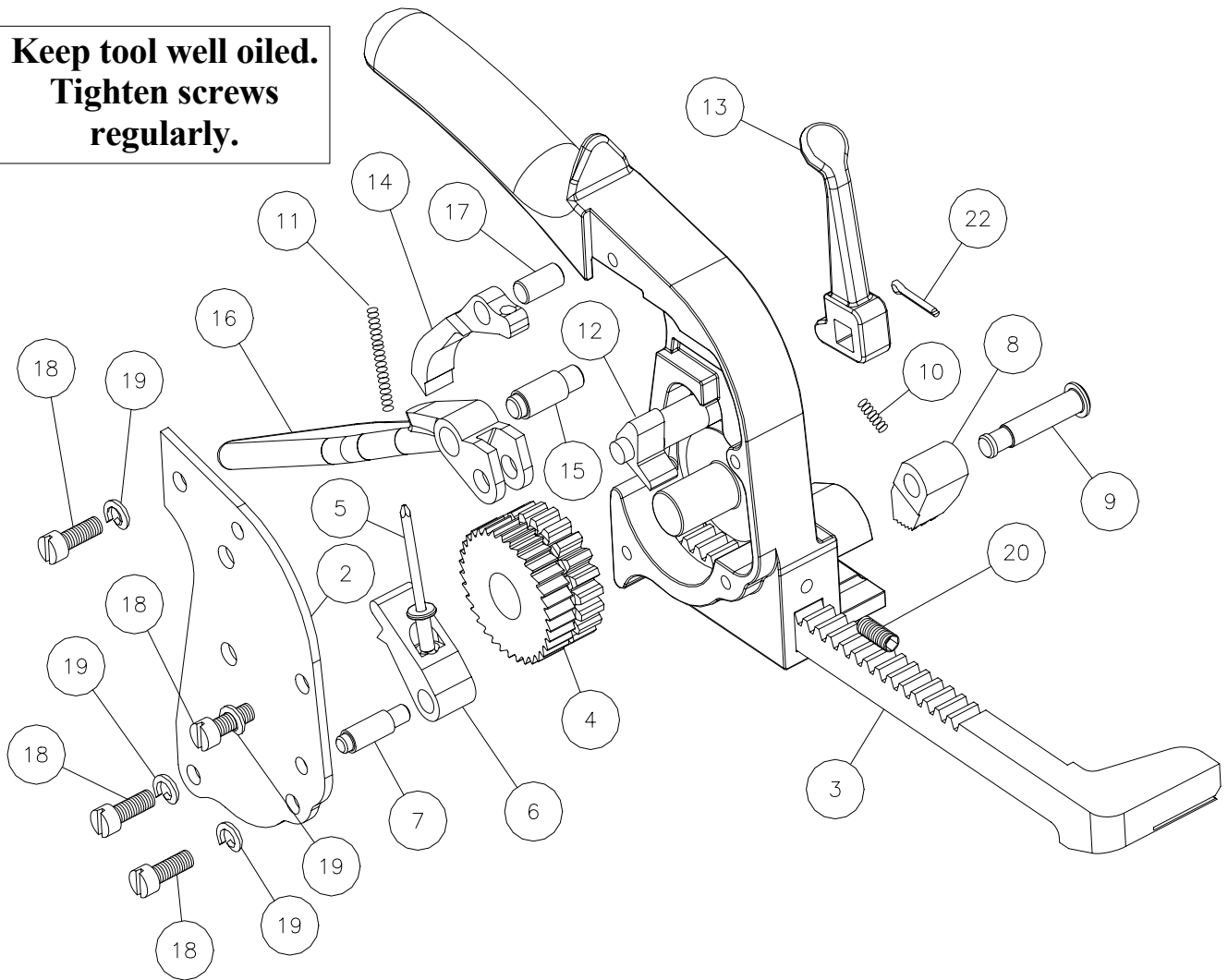

| <u>KEY#</u> | <u>DESCRIPTION</u> | <u>QTY</u> | <u>PART#</u> | <u>KEY#</u> | <u>DESCRIPTION</u> | <u>QTY</u> | <u>PART#</u> |
|-------------|---------------------|------------|--------------|-------------|---------------------|------------|--------------|
| 1 | Body | 1 | M1800-1 | 12 | Release Shaft | 1 | M1800-12 |
| 2 | Cover Plate | 1 | M1800-2 | 13 | Release Lever | 1 | M1800-13 |
| 3 | Pusher Bar | 1 | M1800-3 | 14 | Pulling Pawl | 1 | M1800-14 |
| • 4 | Ratchet Wheel | 1 | M1800-4 | 15 | Tension Lever Shaft | 1 | M1800-15 |
| 5 | Pop Rivet | 1 | M1800-5 | 16 | Tension Lever | 1 | M1800-16 |
| • 6 | Holding Pawl | 1 | M1800-6 | 17 | Dowel Pin | 1 | M1800-17 |
| 7 | Holding Pawl Shaft | 1 | M1800-7 | 18 | Machine Screw | 4 | M1800-18 |
| • 8 | Holding Dog | 1 | M1800-8 | 19 | Lock Washer | 4 | M1800-19 |
| 9 | Holding Dog Shaft | 1 | M1800-9 | 20 | Set Screw | 1 | M1800-20 |
| • 10 | Holding Dog Spring | 1 | M1800-10 | • 22 | Cotter Pin | 1 | M1800-22 |
| • 11 | Holding Pawl Spring | 1 | M1800-11 | | | | |

Reference part number when ordering.

• **Key wear part**

Read all operating & safety instructions on reverse.

Prices subject to change without notice.

MIP-1800 OPERATING INSTRUCTIONS

OPERATING INSTRUCTIONS:

1. Press release lever (Key #13) to push the pusher bar (Key #3) all the way back to the body of the tool.
2. Pull strapping from cart and bring around load. Push seal on with flat side of seal facing outside of strap. (Figure 1)
3. Slide end of strap through bottom of seal and fold over the end to form a "hook." (Figure 2) Pull strap snug about package.
4. Slide tool onto top strap, feeding strap under holding dog (Key #8) and through pusher bar slot (Key #3) with the seal against the nose of the tool. (Figure 3) Be sure the strap is flush with the inside edge of the MIP-1800.
5. Tighten strap by squeezing and releasing the tension handle (Key #16) repeatedly.
6. Fasten the pusher seal with the appropriate tool, according to manufacturer's instructions.
7. With seal secured, tilt the whole tool forward over the seal and back again approximately three times to bend and break the banding. Slide the MIP-1800 off the end of the strapping.

SAFETY WARNINGS:

- Before operating the tool, review the enclosed MIP, Inc. General Hand Tools and Strapping Safety booklet. Only trained personnel should operate MIP, Inc. hand tools.
- Only use equipment recommended for the strap. The MIP-1800 is recommended only for 3/8" x .015 through 5/8" x .023 gauge steel.
- Dangerous breakage may occur due to excessive tensioning, possibly resulting in severe injury or death. Tension strap in moderation.
- Keep fingers away from areas that can pinch or cut.
- Review the instructions and safety material on a regular basis.
- **Warning:** Unsafe use may result in blindness, severe laceration, amputation, or death.

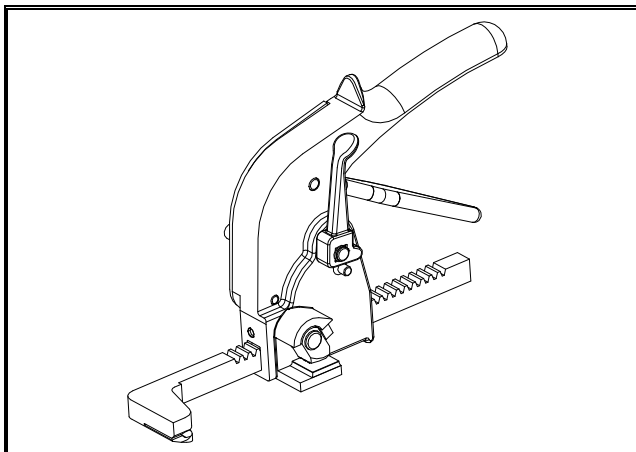

Figure 1

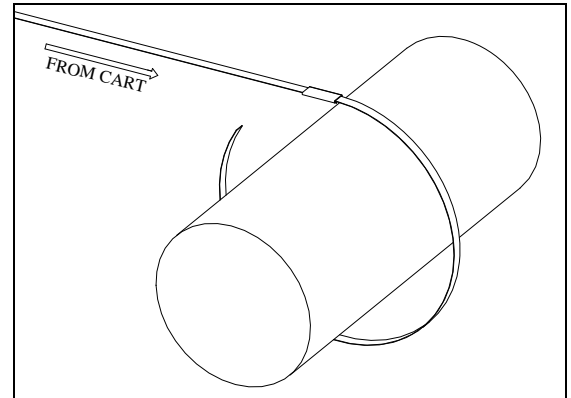

Figure 2

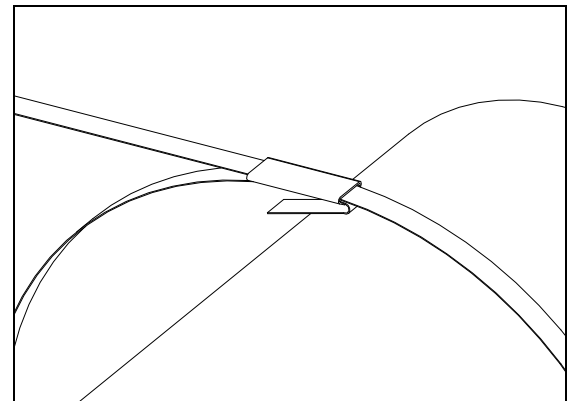

Figure 3

